

CRYSTAL
engineering corporation

GaugeCalXP

PRESSURE COMPARATOR 10 000 PSI / 700 bar / 70 MPa

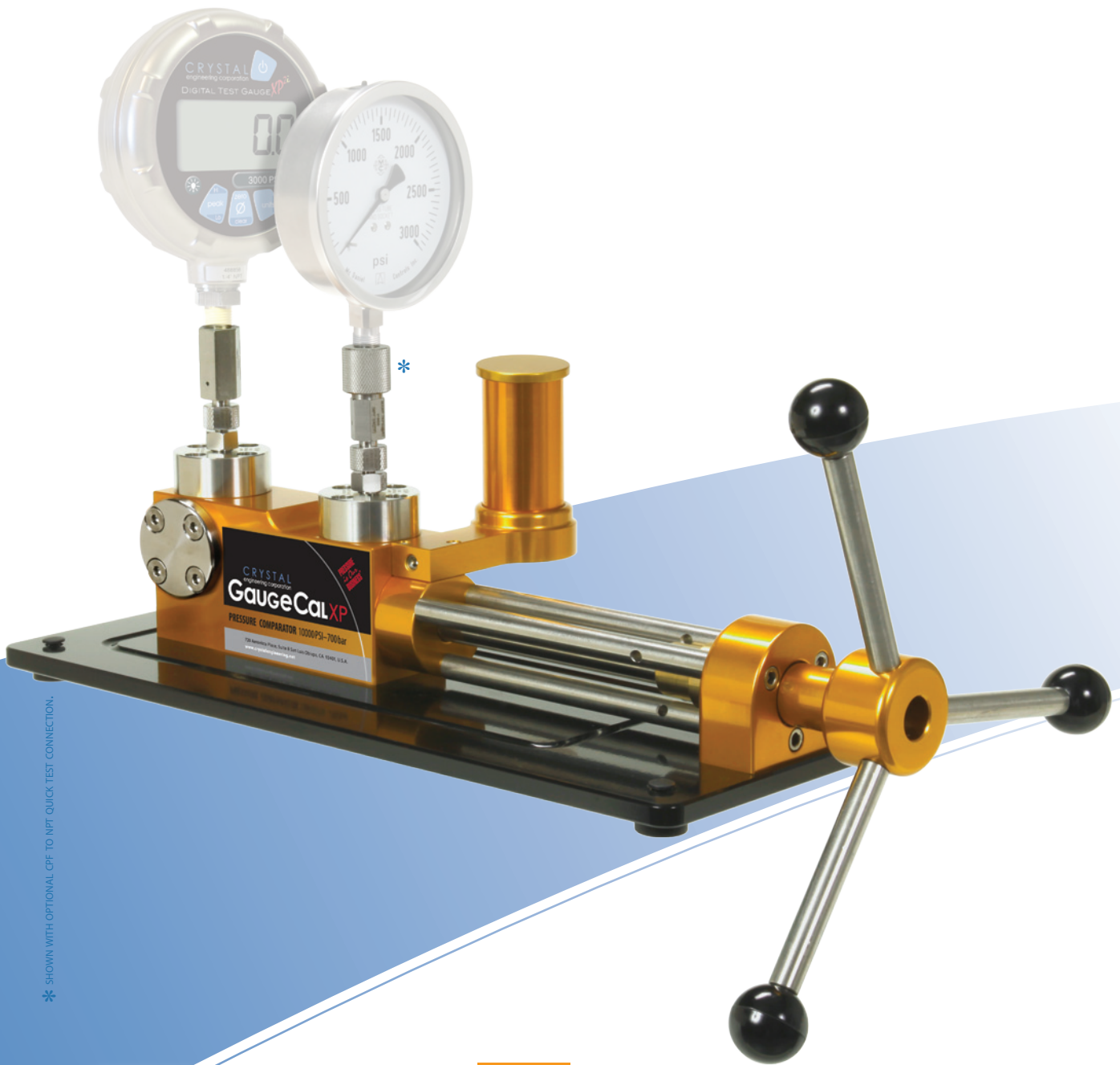

* SHOWN WITH OPTIONAL CPF TO NPT QUICK TEST CONNECTION.

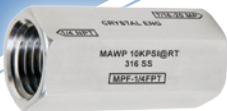

NEW! Now includes the time-saving CPF system!

Unique Design

- Handle does not extend—only the piston moves.

Save Time!

The GaugeCalXP, used with a Crystal reference gauge, is much faster to use than a deadweight tester. It's also faster than most automated pressure controllers, but GaugeCalXP costs much less than either.

Quickly Test and Calibrate

- Gauges
- Chart Recorders
- Transmitters
- Sensors
- Switches
- Relief Valves
- and much more

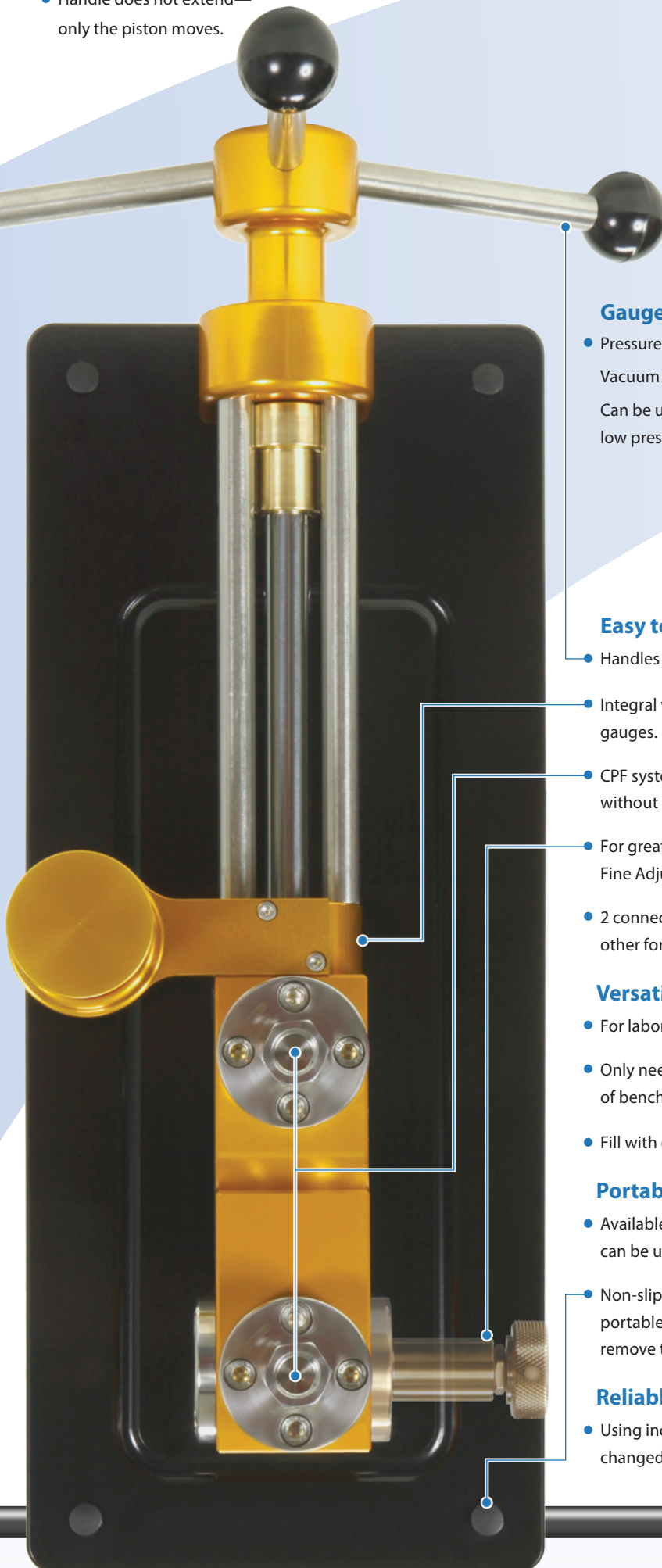

GaugeCalXP Pressure Comparator

- Pressure to 10 000 PSI / 70 MPa / 700 bar.
- Vacuum to -12 PSI / -80 kPa / -0.08 bar.
- Can be used without fluid for low pressure work.

Easy to Use

- Handles make it easy to set any pressure.
- Integral valve prevents damage to mechanical gauges.
- CPF system makes fast, leak free connections without any tools.
- For greater precision, add the Fine Adjust kit option.
- 2 connections, one for your reference, the other for the device being tested.

Versatile

- For laboratory, workshop, or field use.
- Only needs 175 mm x 429 mm (7" x 17") of bench space.
- Fill with oil, hydraulic fluid, water, or nothing!

Portable

- Available lightweight wheeled case, which can be used as a mounting bench.
- Non-slip rubber feet for low pressure or portable use. (For high pressure applications, remove the feet for bench mounting.)

Reliable

- Using included allen keys, all seals can be changed in less than 30 minutes.



Superior to hydraulic hand pumps

The lightweight wheeled case is the most versatile and compact way to travel with the GaugeCalXP, and a practical field alternative to frustrating hand pumps. This case has room for fittings, tools and reference gauges. Included are straps to attach the GaugeCalXP so that case can be used as a field bench.

Pressure is precisely set with a simple turn of the handle, allowing you to calibrate gauges quickly and accurately.

The GaugeCalXP can quickly produce pressures up to 10 000 PSI / 700 bar. An optional Fine Adjust accessory is recommended if calibrating extremely sensitive devices, such as digital pressure gauges. You can also use the GaugeCalXP pressure generator **without** fluid for calibrating differential pressure transmitters. Smooth, continuous pressure generation to 400 inches H₂O (995 mbar), easily set to within 0.01 inches H₂O (0.025 mbar) without fear of over pressurization.

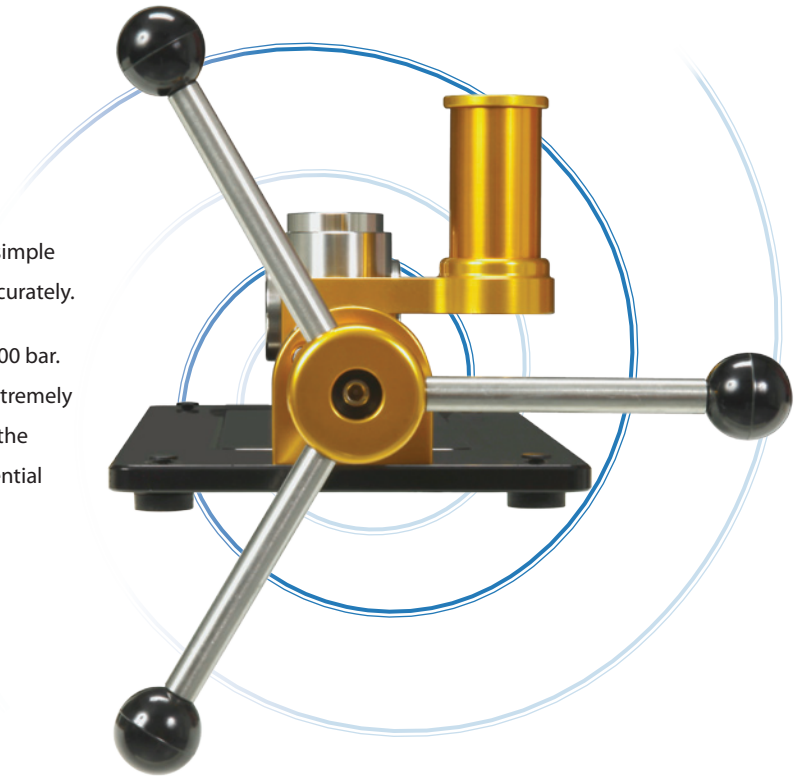

Also try
the super flexible
CPF high pressure
hoses.

CPF Crystal Pressure Fittings™

Leak free
connections
without tools,
even at -20C!
And a
1" minimum bend
radius!

The new Crystal Pressure Fittings (CPF) system quickly and safely makes leak free connections without the use of tools.

A wide range of conversion fittings are available that convert CPF to all common thread types. Especially recommended are the NPT adapters that seal without thread tape or wrenches — a tremendous time saver!

The GaugeCalXP is fitted with two CPF bases and two sets of CPF to female NPT conversion fittings, so it is ready to use with male 1/4NPT gauges.

CPF fittings are compatible with fittings from HIP and Autoclave. See the CPF brochure for details.

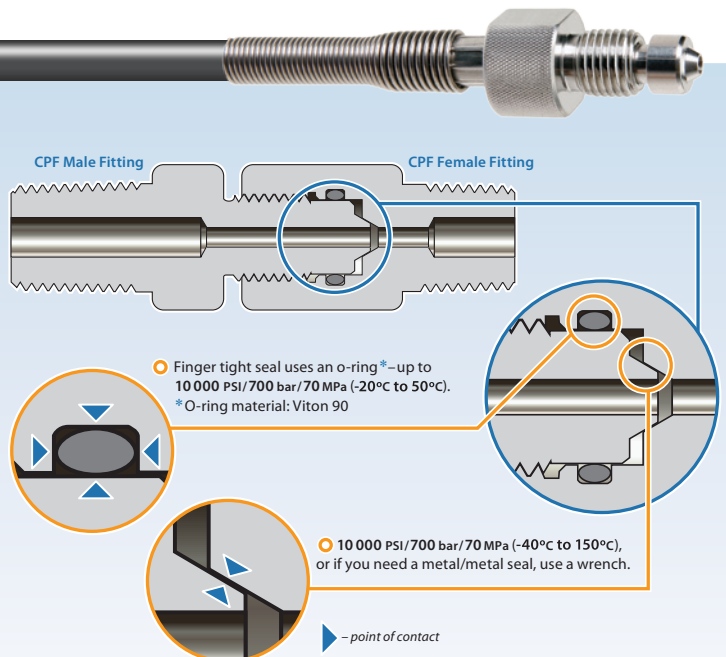

Ordering Information

Pressure Comparator

GaugeCalXP* Pressure Comparator (up to 10 000 PSI)

GaugeCalXP-Skydrol† Pressure Comparator, Skydrol compatible, includes Fine Adjust option and rebuild kit

* Includes 2 CPF male-male fittings (P/N MPM-MPM) and 2 CPF 1/4" FNPT fittings (P/N MPF-1/4FPT).

† Contact Crystal for part numbers and pricing of any individual Skydrol compatible fittings.

Options

3205 Fine Adjust kit

3395 Rolling Case for GaugeCalXP, also includes (2) MPF-CAP Fittings, (2) hold-down straps, and fluid bottle

4138 Rebuild kit for GaugeCalXP

4158 Rebuild Kit for GaugeCalXP-Skydrol

CPF Fittings

CPF fittings connect quickly, safely and without leaks. High quality CPF conversion fittings save even more time when connecting NPT by eliminating thread tape too! See the CPF brochure for more information.



Fitting Kits

4012 GaugeCalXP CPF Upgrade—connects to nVision, XP2i, and M1 Upgrade previous versions of the GaugeCalXP to use the CPF fitting system.

Includes:

MPF-GC (2), **MPF-1/4FPT** (2), **MPM-MPM** (2)

4013 Quick Test NPT Kit – Finger-tight to working pressure up to 10 000PSI/700 bar

A set of CPF conversion fittings for connecting to 1/8", 1/4" and 1/2" male NPT – without tools or thread tape.

Includes:

MPF-1/8QTF (1), **MPF-1/4QTF** (1), **MPF-1/2QTF*** (1)

*MPF-1/2QTF finger-tight to working pressure up to 5 000 PSI / 350 bar

4015 BSP Test Kit – Working pressure up to 10 000PSI/700 bar

CPF conversion fittings to connect to male BSP: G 1/8, G 1/4, G 3/8 and G 1/2.

Includes:

MPF-1/8BSPF (1), **MPF-1/4BSPF** (1), **MPF-3/8BSPF** (1), **MPF-1/2BSPF** (1)



Specifications

Performance

Hydraulic

Maximum Pressure 10 000 PSI / 700 bar

Minimum Pressure 5 PSI / 0.5 bar

Pneumatic

Maximum Pressure 400 in H₂O / 995 mbar

Sensitivity 0.01 in H₂O / 0.025 mbar

Burst Pressure >20 000 PSI / 1400 bar

Materials

Ram/Adapters 316SS

Body Anodized Aluminum

Seals (Standard) Buna N (Nitrile)

Seals (Skydrol-compatible) EPDM

Test Media Water, Oil, or Air

Dimensions

Width (of base) 175mm (6.88")

Length (of base) 429mm (16.88")

Length (overall) 495mm (19.50")

Weight 6.4kg (14.2 lbs)

Connection

Base CPF

Accessories (included)

Adapters (2) MPF-1/4FPT, (2) MPM-MPM

Wrenches 2

Shipping Information

Shipping Weight 8.6kg (19 lbs)

Dimensions 559mm x 305mm x 229mm

Copyright © 2009 Crystal Engineering Corporation • 708 Fiero Lane, Suite 9, San Luis Obispo, California 93401-8701

No part of this document may be reproduced or modified in any form or by any means, electronic or mechanical, without express written permission from Crystal Engineering Corporation.

Visit us on the web at
www.crystallengineering.net

PN: 3173—Rev D